



CNC High Pressure Water Jet Cutting Machine



V-FLO GROUP OF COMPANIES LTD.

WWW.V-FLO.COM

Machine configuration and main technical data

1. Intensifier pump (APW38037Z-07B)



1.1. Main characters:

- 1.1.1 whole set of intensifier pump from America (Accustream Inc) .
- 1.1.2 One-cylinder and two-direction cycle piston style intensifier components.
- 1.1.3 Single row water filtering system
- 1.1.4 Safeguards from ultra-high pressure
- 1.1.5 Electrical shift
- 1.1.6 It is OK to adjust the pressure by hand continuously and the range is 50-380 MPa.

1.2 Main technical data

- 1.2.1 Max discharge of oil pump: 90L/min
- 1.2.2 Max water discharge: 3.7L/min
- 1.2.3 Max available orifice diameter: 0.3mm
- 1.2.4 Max pressure: 380MPa (55000psi)
- 1.2.5 Continuous working pressure: 320~340MPa
- 1.2.6 Main motor power: 37KW (50Hp)
- 1.2.7 Power supply: 380V/50HZ
- 1.3 Professional tools for machine maintenance will go along with machine
- 1.4 Main wearing parts and spare parts go along with machine
- 1.5 Maintenance manual

2. CNC system

2.1 Main character:

2.1.1 CNC control

2.1.2 Apply IPC: with higher reliability, it's easy to perform human-to-computer talk and real-time control of cutting process. At the same time, it's convenient to deliver and share the files between operator and designer by network

2.1.3 15 Inch LCD is convenient for operator to observe and reduce visual fatigue

2.1.4 Using PLC instead of relay will establish communications with computer



2.2 Professional software for waterjet cutting machine

2.2.1 Original Windows XP based

2.2.2 The speed will decrease automatically when cutting small arcs and around the corner.

2.2.3 The .DXF file generated from AUTOCAD will be transformed to processing program automatically

2.2.4 Have image imitation running function.

2.2.5 Have image input automatic programming function.

3. Cutting table APW-2515BB



3.1 Main characters:

3.1.1 It is of flying arm style, easy to load cutting materials

3.1.2 Using ABBA brand ball screw and linear guide from Taiwan, which guarantees the transmission accuracy, high quality and durability.

3.1.3 X beam of cutting table applies the one-off extrusion forming aluminum alloy

3.1.4 Z-axis goes up and down under electrical control.

3.1.5 apply 3-axis control and automatic alignment

3.1.6 Way of drive: AC servo. Using FUJI brand servomotor and drive from Japan which have reliable control and good acceleration functions. They run steadily and will not generate low frequency resonance.

3.1.7 Overtravel and soft limits, double protection functions.

3.2 Main technical data

3.2.1 Structural style: Flying arm style

3.2.2 Valid processing range: 2500mm×1500mm

3.2.3 Z-axis journey : 400 mm

3.2.4 Control accuracy : ± 0.01 mm

3.2.5 Cutting accuracy: $\pm 0.1-0.2$ mm

4. HP on/off valve and cutting head

4.1 The pneumatic valve can perform the instant on/off of HP water.

4.2 The automatic control can be achieved by assistance function of CNC system.

4.3 It's easy to replace the wearing parts due to the self rectification function of cutting head.

4.4 Nozzle from America, with good quality and more durable.

5. Self-adjusting device

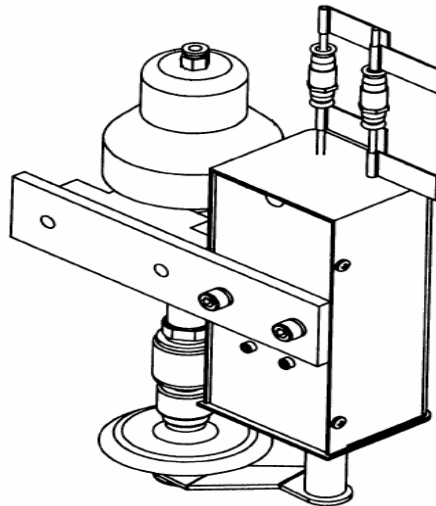

This option provides two main advantages.

- 1) Sheet materials are often subject to warping. The Skip and Float™ feature will ensure the cutting head is maintained at an optimal stand off height above the material being cut (via the float mechanism). Without this feature, warped material can cause the cutting head to get too close to or even touch the material being cut, creating a blockage of the cutting head. If the stand off gets too large, the cut quality will be reduced, or may not cut through the material.
- 2) The skip function automatically raises the cutting head well above the material when rapid traversing between cuts. This ensures that the cutting head cannot catch on a cut part which may have tilted and rose above the material. This will ensure that the focusing tube isn't broken and the work piece isn't moved or damaged.

Benefits include:

- Allows machine to accept warped material
- Ensures efficient cutting due to minimized, constant stand off.
- Reduces risk of crashing on warped materials
- Clamping reduced, with no need o pull the material flat.

6. Auto abrasive delivery system

Auto abrasive delivering system is researched and developed to provide a great convenience to users whose main functions are auto abrasive delivering and lack of abrasive warning. Be of simple structure, simplified operation and easy maintenance, it's auxiliary equipment for working efficiently. Autoabrasive delivering system is using air pressure to deliver abrasive from the Bulk feed abrasive hopper to mini hopper above cutting head. Make the abrasive come into the cutting head by negative pressure and to achieve the purpose of continuous feeding during cutting. When the intensifier pump is on, the electro-magnetic valve on Bulk feed abrasive hopper will open automatically and let air in. When abrasive is less than the min quantity, the Bulk feed abrasive hopper will alarm to remind the operator to feed abrasive in time.



7. Technical data

Item	Data
Power	AC380V50/60Hz
X-axis servomotor	0.75kw
Y-axis servomotor	0.75KW 1.0KW 1.5KW
Z-axis step motor	8.5kg.cm
X-axis max speed	5000mm/min
Y-axis max speed	5000mm/min
Z-axis max speed	1500mm/min
Control accuracy	±0.01mm
Cutting gradient	0-3°
Dia of nozzle	0.26mm 0.30mm
Max cutting gap	<2.5mm
Max delivery capacity	3.0L/min 3.7L/min

8. Dimension

Model	Outside dimension (mm)	Worktable(mm)	Weight (kg)
1210BB	1854X2010X1800	1331X1138	1300
2010BB	2734X2010X1800	2221X1141	1430
2510BB	3234X2010X1800	2711X1141	1460
3018BB	4050X3000X1800	3316X2105	2330
1515BA	2050X3350X1720	1641X1641	1640
1520BA	2050X3350X1720	2125X1641	2000
1525BA	3660X2320X1720	2605X1641	2010
1530BA	4060X2320X1720	3105X1641	2380
2015BA	2550X2550X1720	2141X1641	1710
2025BA	3660X2820X1720	2605X2141	2400
2030BA	4060X2820X1720	3151X2141	2670
2035BA	4606X2820X1720	3651X2141	2920