



Bag Splitting Machine



V-FLO GROUP OF COMPANIES LTD.

WWW.V-FLO.COM

Specification

Automatic bag splitting machine is used for splitting bags and feed material, the material are powder or granule in the form of bags. It is consisted by conveyer belt, knife equipment, shaking sifter,screw equipment, crust, bracket, dust catcher, transportation equipment and electrical controller. The are many kinds of material, such as calcareousness, MgO, quartz sand, limestone, wood powder, active carbon, milk powder, PVC powder,Urea, Gypsum, Clay and so on. Widely used in chemical plants, petroleum, building material, metallurgy, electrical power, food ,medicine and so on.

It feeds bags through conveyer, then knife equipment splits bags, shaking sifter should separate material and bags,material drops into the hoppers, bags should be callbacked. When working ,dust catcher can filtrate dust, make sure the working condition is clean. The product is high efficient, protecting environment, easy operating and maintaince.

WWW.V-FLO.COM

Material	CS. SS304,SS304L
Structure	Conveyer,knife equipment,shaking sifter,screw equipment, crust, bracket,dust catcher,transportation equipment ,electrical controller
Power	10-17kw
Dimension	According requirment

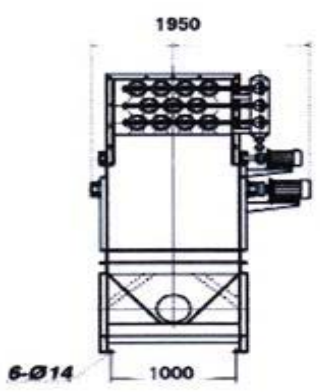
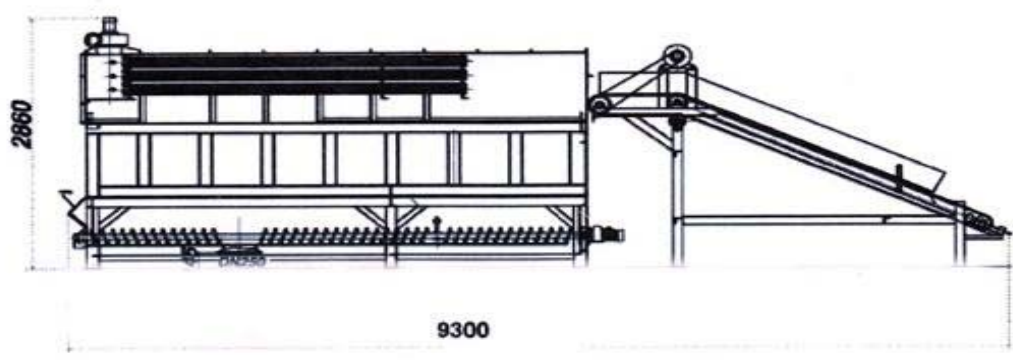

WWW.V-FLO.COM